

◆ 选型 Type Selection

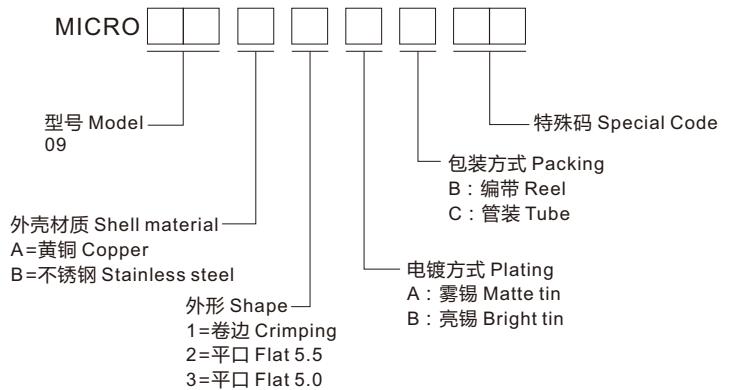

◆ 规格 Specifications

- 电流额定值 Current rating : 1A Max
- 电介质耐电压, 交流100V, 持续1分钟
Dielectric withstanding voltage, AC 100V for 1min
- 接触阻力 Contact resistance : 最大30mΩ Max
- 绝缘电阻 Insulation resistance : 100米/分100MΩ/ Min
- 总交配力 Total mating force : 最大3.57 kgf3.57Kgf Max
- 总脱配力 Total unmating force :
1.0 kgf/min, 0.81 ~ 2.05 kgf/min, 经10000次插拔循环后
1.0Kgf Min.0.81~2.05Kgf Min.after 10000 insertion/extraction cycles
- 温度范围 Temperature range : -30°C ~ 80 °C

◆ 材质 Material

- 端子 Terminal : 铜合金 Copper Alloy
- 本体 Ontology : LCP UL94V-0

◆ 图表 Diagram

- 09A1 (全贴卷边有柱)

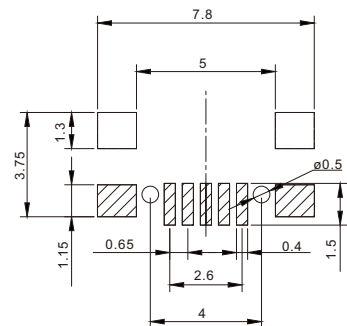
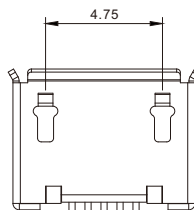
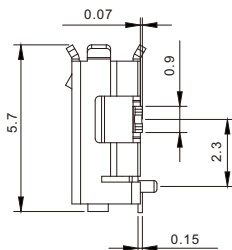
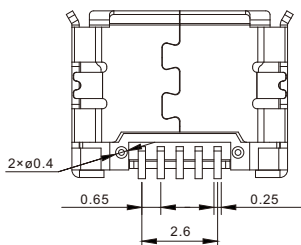
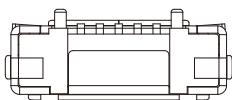

安装图
instructions

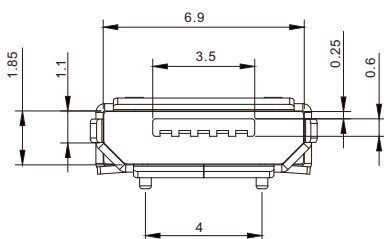

■ 09A03 (全贴平口5.0有柱)

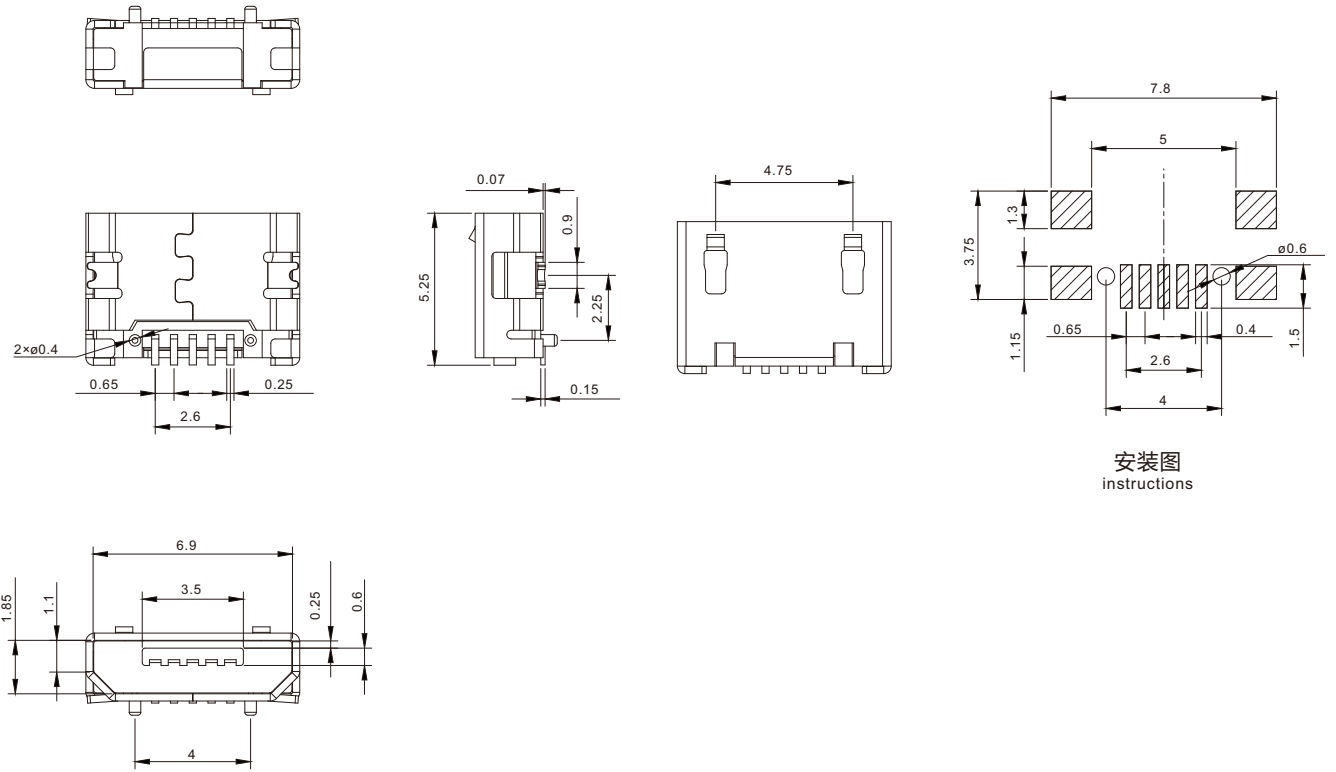

■ 09A02 (全贴平口5.5有柱)

